



TW6864

4-Channel Multi-Standard Video and Audio Decoder with PCIe Interface

Target Application

- PCI Express DVR Card

The TW6864 is a highly integrated single-chip solution that supports multi-channel real time video and audio capture via PCIe x1 interface for PC DVR applications. It contains four high quality NTSC/PAL/SECAM video decoders that convert analog composite video signal to digital component YCbCr data, and utilizes an adaptive 4H comb filter for separating luminance and chrominance to reduce cross noise artifacts. TW6864 contains a high performance proprietary DMA controller that fully utilizes the PCIe x1 bandwidth, enabling it to transfer video and audio data at optimal throughput rate.

TW6864 has the versatility to support a wide variety of video applications, including decoding and transferring 4 channel real-time D1 video, or up to 16 channel non-real-time video simultaneously. It supports multiple video display formats such as D1, half D1 and CIF. By implementing Techwell's advanced proprietary video-switching technology, TW6864 also possesses industry-leading video-locking speed in non-real-time switching mode.

Key Features

- Internal 4-channel video decoder and audio ADC
- High quality proprietary fast video locking system for non-real-time application
- PCI Express Base Specification 1.1 and 2.0 Compliant
- Supports 4-channel D1 video plus 5-channel audio simultaneously with independent channel control
- Dynamic synchronization video processing; and multiple video format output support: Y422, Y420, IYUI/Y411, Y41P, RGB555 and RGB565
- Dual support for both Direct Show and Direct Draw

Video Decoder

- Accepts all NTSC(M/N/4.43) / PAL(B/D/G/H/I/K/L/M/N/60) / SECAM standards with auto detection
- Integrated four video analog anti-alias filters and 10 bit CMOS ADCs
- IF compensation filter for improvement of color demodulation
- Color Transient Improvement (CTI)
- White peak AGC control
- Programmable hue, saturation, contrast, brightness and sharpness
- High performance adaptive 4H comb filters for all NTSC and PAL standards

Audio Capture

- Software selectable 4 channel analog sound inputs
- 10-bit ADC for analog sound digitizing, 8-/16-bits audio support (8/16/32/44.1/48KHz)
- Up to 16-bit I²S stereo digital input
- Programmable sampling rate generation
- 4 single-channel audio output plus one channel mixed audio output

TW6864 Typical System Solution Diagram

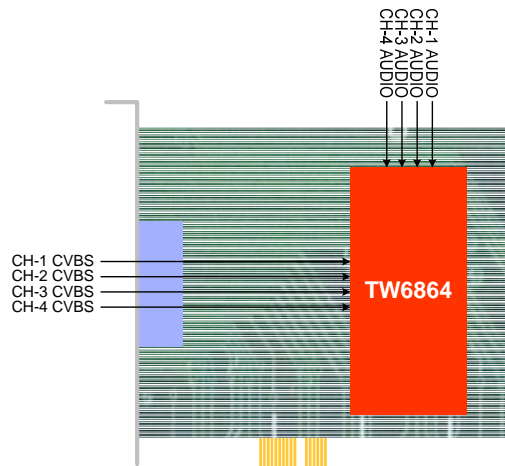

TW6864

4-Channel Multi-Standard Video and Audio Decoder with PCIe Interface

TW6864 Block Diagram

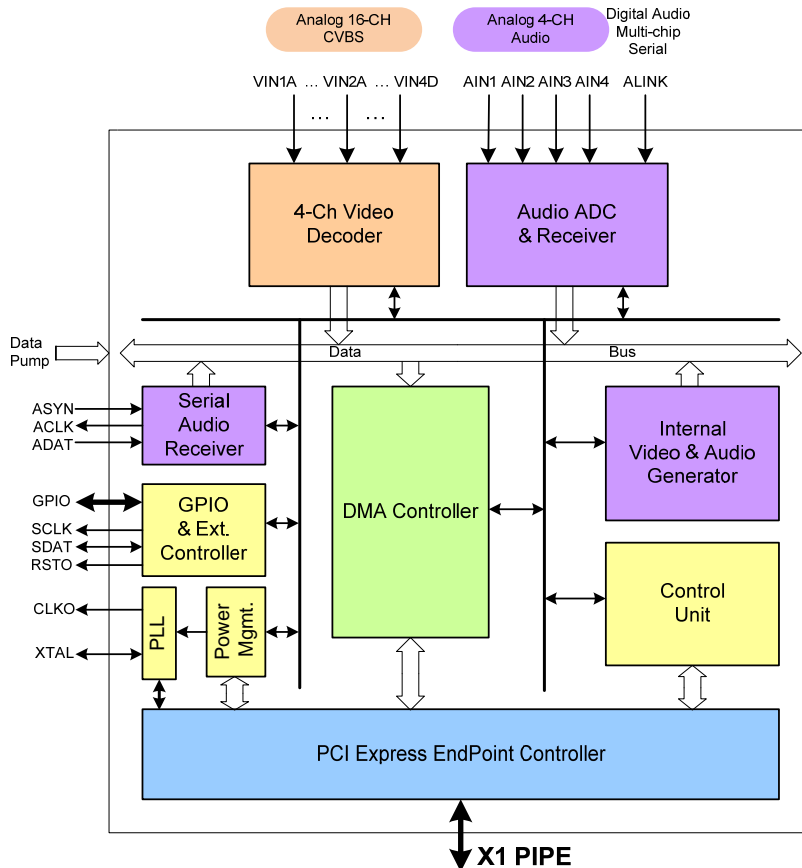

Miscellaneous

- Supports 108 MHz mux digital 656 video data
- 16-pin GPIO
- Single 27MHz oscillator for all standards
- 3.3V tolerant I/O
- 1.8V power supply
- 160-pin LQFP Package

Order Information

Product	Real-Time Maximum Channel	Non-Real-Time Maximum Channel	Cascade-able with Techwell's TW286x
TW6864	4-CH D1/Half D1/CIF + 5-CH Audio	16-CH D1/Half D1/CIF + 5-CH Audio	N/A

About Techwell

Techwell is a semiconductor company that designs, markets and sells mixed signal integrated circuits for multiple video applications in the security surveillance, automotive and consumer electronics markets. Techwell designs both general purpose and application specific products that enable the conversion of analog video signals to digital form and perform advanced digital video processing to facilitate the display, storage and transport of video content. Headquartered in San Jose, CA, Techwell currently has over 165 employees in the U.S., Korea, Taiwan, China and Japan.